



## 101101 HYDROFLASH MEDIUM LED

Round floodlight for outdoor installation on a façade/wall. Phospho-chromatised and polyester powder coated die-cast copper-free aluminium body, tempered safety glass, moulded silicone gasket and stainless steel screws. Built-in LED driver 220-240V 50-60Hz, with 5 CREE XP-G3 high-power LED. IP65 rating.

### Energy Label **A++**

- Material: high corrosion resistance die-cast copper-free aluminum body
- Coating: polyester powder coating with phosphochromating pre-finish
- NR. 5 CREE "XP-G3" LED
- Electronic transformer 220/240V 50/60Hz included
- Stainless steel screws
- Silicone rubber gasket
- Tempered safety glass.
- Double nickel-plated brass cable gland PG11
- 1 mt. neoprene power cable included



1-10 V DIMMABLE / DALI VERSION  
AVAILABLE ON REQUEST



AVAILABLE ON REQUEST

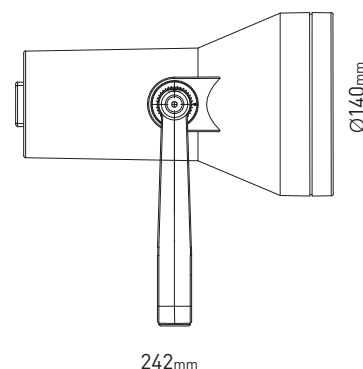
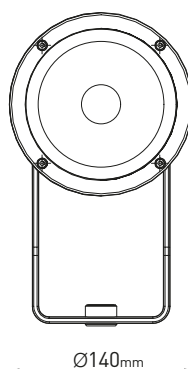
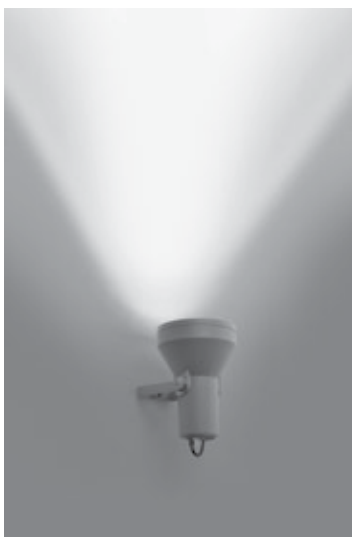
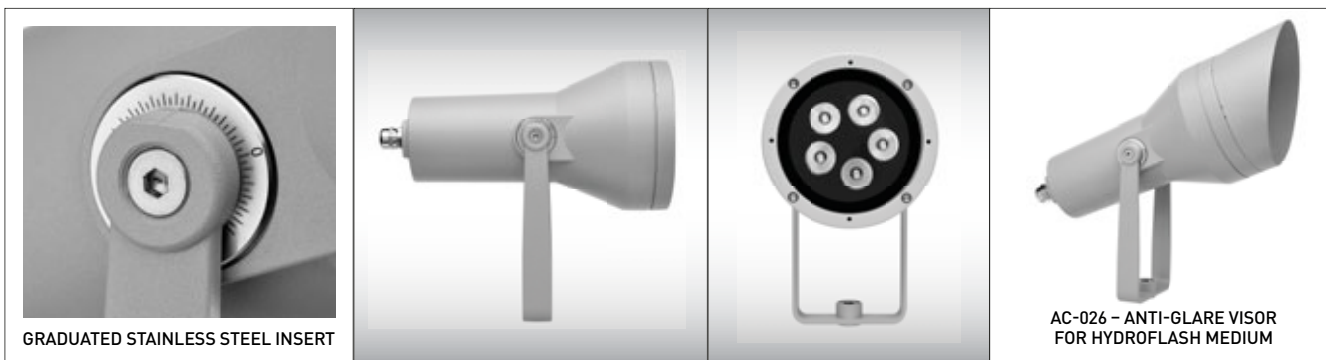

8 WATT  
220-240V 50-60HZ ELECTRONIC  
IP65 - CE

2,60 KG UNIT GROSS WEIGHT

LIGHT SOURCE	LED COLOR*	LIGHT BEAM OPTIONS	LUMEN OUTPUT (lm)	LUMINOUS EFFICACY (lm/w)	COLORS OPTIONS
HIGH-POWER LED	3.000°K WARM-WHITE	10°	720	90.00	<input checked="" type="checkbox"/> TEXTURED GREY <input type="checkbox"/> MATT WHITE (ON REQUEST) <input checked="" type="checkbox"/> MATT BLACK (ON REQUEST)
		30°	684	85.50	
		45°	650	81.25	
	4.000°K NEUTRAL-WHITE	10°	750	93.75	
		30°	713	89.13	
		45°	677	84.63	

\* OTHER LIGHT COLORS AVAILABLE ON REQUEST: BLUE





## 101102 HYDROFLASH MEDIUM COB LED

Round floodlight for outdoor installation on a façade/wall. Phospho-chromatised and polyester powder coated die-cast copper-free aluminium body, tempered safety glass, moulded silicone gasket and stainless steel screws. Built-in LED driver 220-240V 50-60Hz, with 1 CREE CXA 1512 COB LED. IP65 rating.

### Energy Label **A++**

- Material: high corrosion resistance die-cast copper-free aluminum body
- Coating: polyester powder coating with phosphochromating pre-finish
- NR. 1 CREE CXA 1512 LED
- Electronic transformer 220/240V 50/60Hz included
- Stainless steel screws
- Silicone rubber gasket
- Tempered safety glass.
- Double nickel-plated brass cable gland PG11
- 1 mt. neoprene power cable included



1-10 V DIMMABLE / DALI VERSION  
AVAILABLE ON REQUEST

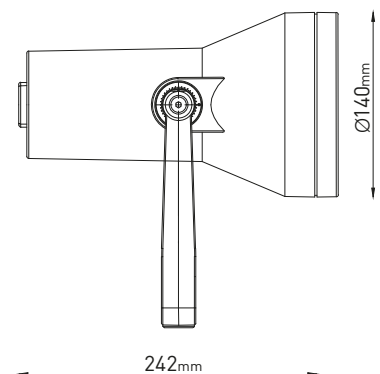
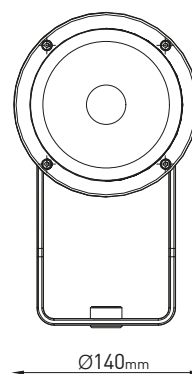
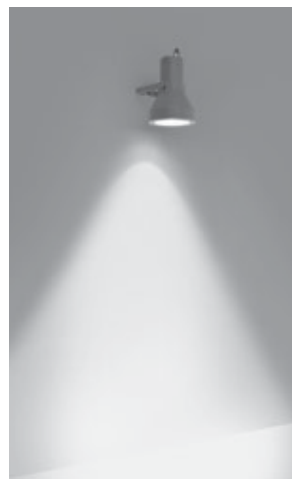

	LIGHT SOURCE	LED COLOR*	LIGHT BEAM OPTIONS	LUMEN OUTPUT (lm)	LUMINOUS EFFICACY (lm/w)	COLORS OPTIONS
18 WATT 220-240V 50-60HZ ELECTRONIC IP65 2,60 KG UNIT GROSS WEIGHT	COB LED	3.000°K WARM-WHITE	M 35°	1.530	85.00	<input type="checkbox"/> TEXTURED GREY <input type="checkbox"/> MATT WHITE (ON REQUEST) <input type="checkbox"/> MATT BLACK (ON REQUEST)





## 101103 HYDROFLASH MAXI LED

Round floodlight for outdoor installation on a façade/wall. Phospho-chromatised and polyester powder coated die-cast copper-free aluminium body, tempered safety glass, moulded silicone gasket and stainless steel screws. Built-in LED driver 220-240V 50-60Hz, with 8 CREE XP-G3 high-power LED. IP65 rating.

### Energy Label **A++**

- Material: high corrosion resistance die-cast copper-free aluminum body
- Coating: polyester powder coating with phosphochromating pre-finish
- NR. 8 CREE "XP-G3" LED
- Electronic transformer 220/240V 50/60Hz included
- Stainless steel screws
- Silicone rubber gasket
- Tempered safety glass.
- Double nickel-plated brass cable gland PG11
- 1 mt. neoprene power cable included



1-10 V DIMMABLE / DALI VERSION AVAILABLE ON REQUEST



AVAILABLE ON REQUEST



GRADUATED STAINLESS STEEL INSERT



AC-027 - ANTI-GLARE VISOR FOR HYDROFLASH MEDIUM

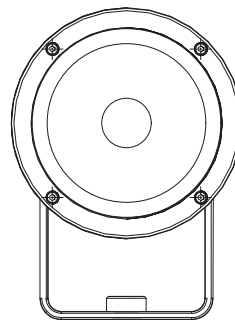

Ø198mm

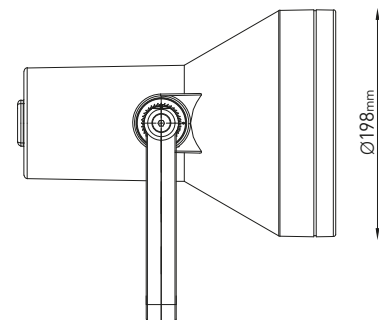

Ø198mm

277mm

12 WATT  
220-240V 50-60HZ ELECTRONIC  
IP65  
3,50 KG UNIT GROSS WEIGHT

LIGHT SOURCE	LED COLOR*	LIGHT BEAM OPTIONS	LUMEN OUTPUT (lm)	LUMINOUS EFFICACY (lm/w)	COLORS OPTIONS
HIGH-POWER LED	3.000°K WARM-WHITE	10°	1.152	96.00	<input type="checkbox"/> TEXTURED GREY  <input type="checkbox"/> MATT WHITE (ON REQUEST)  <input type="checkbox"/> MATT BLACK (ON REQUEST)
		30°	1.095	91.25	
		45°	1.040	86.67	
	4.000°K NEUTRAL-WHITE	10°	1.200	100.00	
		30°	1.140	95.00	
		45°	1.083	90.25	

\* OTHER LIGHT COLORS AVAILABLE ON REQUEST: BLUE





## 101104 HYDROFLASH MAXI COB LED

Round floodlight for outdoor installation on a façade/wall. Phospho-chromatised and polyester powder coated die-cast copper-free aluminium body, tempered safety glass, moulded silicone gasket and stainless steel screws. Built-in LED driver 220-240V 50-60Hz, with 1 CREE CXB 2530 COB LED. IP65 rating.

### Energy Label **A++**

- Material: high corrosion resistance die-cast copper-free aluminum body
- Coating: polyester powder coating with phosphochromating pre-finish
- NR. 1 CREE CXB 2530 LED
- Electronic transformer 220/240V 50/60Hz included
- Stainless steel screws
- Silicone rubber gasket
- Tempered safety glass.
- Double nickel-plated brass cable gland PG11
- 1 mt. neoprene power cable included



1-10 V DIMMABLE / DALI VERSION  
AVAILABLE ON REQUEST

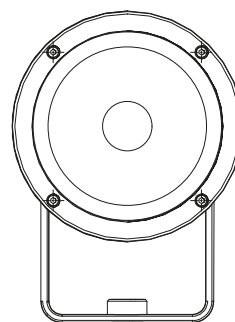

Ø198mm

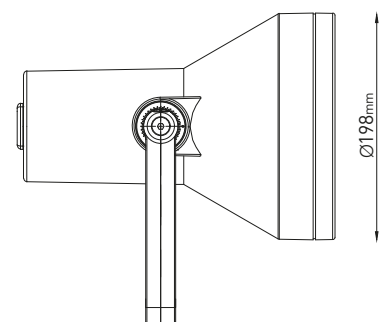

277mm

Ø198mm

	LIGHT SOURCE	LED COLOR*	LIGHT BEAM OPTIONS	LUMEN OUTPUT (lm)	LUMINOUS EFFICACY (lm/w)	COLORS OPTIONS
36 WATT 220-240V 50-60HZ ELECTRONIC IP65 3,50 KG UNIT GROSS WEIGHT	COB LED	3.000°K WARM-WHITE	M 35°	3.100	86.10	<input type="checkbox"/> TEXTURED GREY <input type="checkbox"/> MATT WHITE (ON REQUEST) <input type="checkbox"/> MATT BLACK (ON REQUEST)





## 101105 HYDROFLASH MEGA LED

Round floodlight for outdoor installation on a façade/wall. Phospho-chromatised and polyester powder coated die-cast copper-free aluminium body, tempered safety glass, moulded silicone gasket and stainless steel screws. Built-in LED driver 220-240V 50-60Hz, with 15 CREE XP-G2 high-power LED. IP65 rating.

### Energy Label **A++**

- Material: high corrosion resistance die-cast copper-free aluminum body
- Coating: polyester powder coating with phosphochromating pre-finish
- NR. 15 CREE "XP-G2" LED
- Electronic transformer 220/240V 50/60Hz included
- Stainless steel screws
- Silicone rubber gasket
- Tempered safety glass.
- Double nickel-plated brass cable gland PG11
- 1 mt. neoprene power cable included

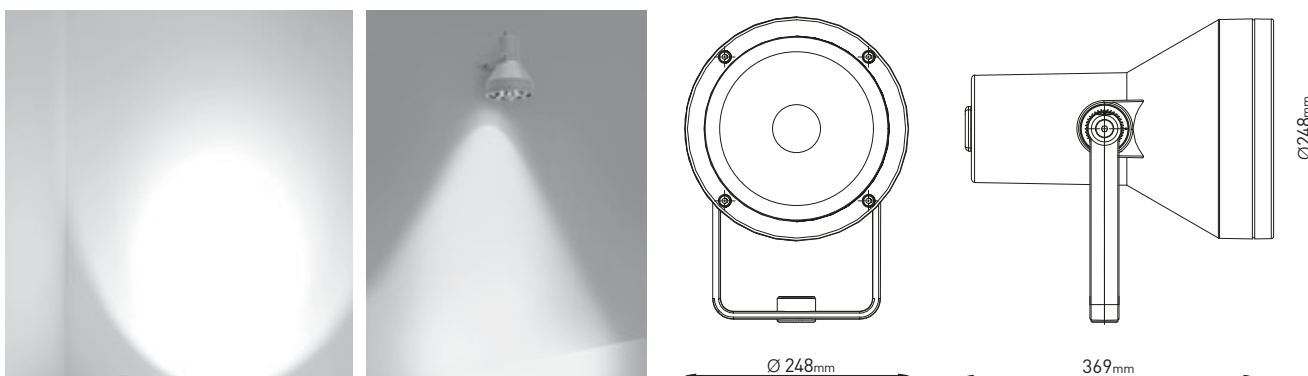

LIGHT SOURCE	LED COLOR*	LIGHT BEAM OPTIONS	LUMEN OUTPUT (lm)	LUMINOUS EFFICACY (lm/w)	COLORS OPTIONS
HIGH-POWER LED	3.000°K WARM-WHITE	M 10°	2.160	98.18	<input type="checkbox"/> TEXTURED GREY  <input type="checkbox"/> MATT WHITE (ON REQUEST)  <input type="checkbox"/> MATT BLACK (ON REQUEST)
		M 30°	2.052	93.27	
		M 45°	1.949	88.60	
	4.000°K NEUTRAL-WHITE	M 10°	2.250	102.28	
		M 30°	2.137	97.14	
		M 45°	2.030	92.27	

22 WATT  
220-240V 50-60HZ ELECTRONIC  
IP65  
5,00 KG UNIT GROSS WEIGHT





## 101106 HYDROFLASH MEGA COB LED



Round floodlight for outdoor installation on a façade/wall. Phospho-chromatised and polyester powder coated die-cast copper-free aluminium body, tempered safety glass, moulded silicone gasket and stainless steel screws. Built-in LED driver 220-240V 50-60Hz, with 1 CREE CXB 3070 COB LED. IP65 rating.

### Energy Label **A++**

- Material: high corrosion resistance die-cast copper-free aluminum body
- Coating: polyester powder coating with phosphochromating pre-finish
- NR. 1 CREE CXB 3070 COB LED
- Electronic transformer 220/240V 50/60Hz included
- Stainless steel screws
- Silicone rubber gasket
- Tempered safety glass.
- Double nickel-plated brass cable gland PG11
- 1 mt. neoprene power cable included

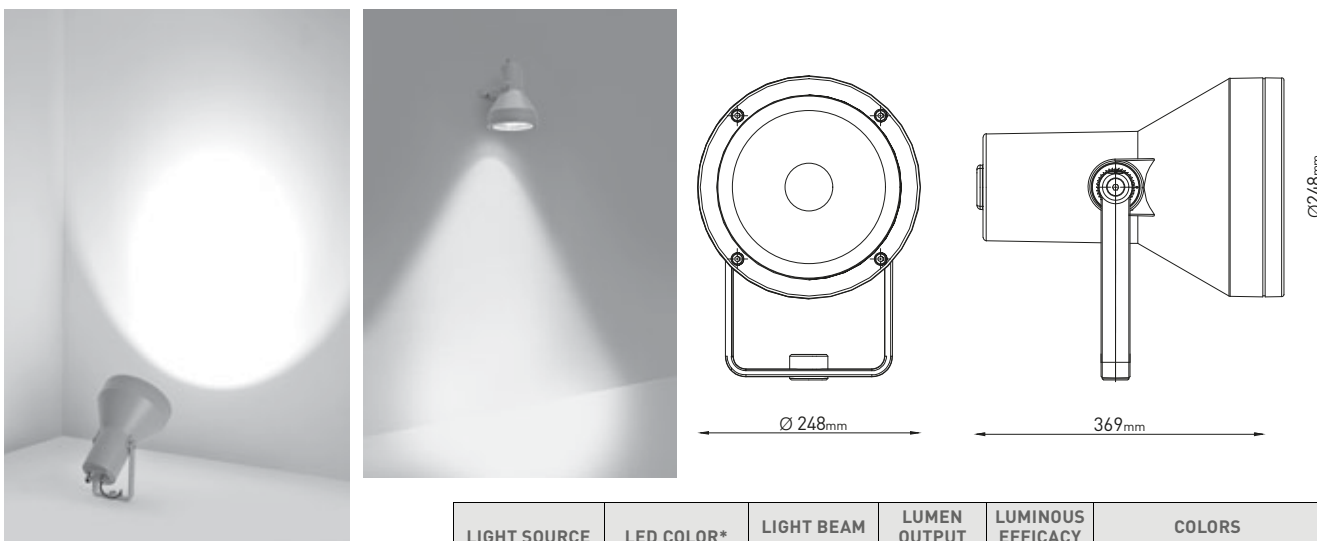

	LIGHT SOURCE	LED COLOR*	LIGHT BEAM OPTIONS	LUMEN OUTPUT (lm)	LUMINOUS EFFICACY (lm/w)	COLORS OPTIONS
55 WATT 220-240V 50-60HZ ELECTRONIC IP65 5,00 KG UNIT GROSS WEIGHT	COB LED	3.000°K WARM-WHITE	35°	4.730	86.00	TEXTURED GREY MATT WHITE (ON REQUEST) MATT BLACK (ON REQUEST)





