

SHILUVIT

Solid Wood Ceilings &
Wall Claddings



ORANIT

WOOD PROFILES INDUSTRIES Ltd.

Oranit Wood Profiles Industries

Oranit is a privately-owned leading producer of wood profiles and ceilings, established in 1985 as a small family timber warehouse

The 5000m² factory is located in the Haifa Bay Industrial Zone, Israel, very close to Haifa port.

Oranit offers a wide range of quality products, either standard or tailor-made, meeting the highest design, technology and environmental standards.

It is our goal to maintain the highest international standards and keep up with products and marketing trends and demands. In order to do this, we employ the most advanced equipment and techniques. Oranit is a vertically integrated manufacturing company- all processes are being done under one roof: sawing, moulding, CNC cross cut, fire retardant treatment, varnishing, staining and wood preservation.



Oranit is represented across Europe by loyal, long-term customers. We regularly exhibit our products and new ideas in international fairs.



Should our customers require new design, different wood species, new stains, etc., we shall follow their request. As we have all facilities of production at hand, we can be flexible to accommodate new designs and trends.

Oranit is highly committed to protect the environment. We treat wood as nature's gift - we purchase timber from sustainable and legally harvested sources only. All materials used in production, including fire retardant, varnishes and stains, are 100% environmentally friendly.

Oranit is PEFC certified for Chain of Custody management system, and employs a Due Diligence System to ensure all products meet the EU Timber Regulations (EUTR).

All stages of production are strictly quality controlled. Oranit is certified with ISO 9001: 2008 quality control management system.



Fire safety

Shiluvit wood products meet the highest European fire safety standards for wood ceilings and wall cladding.



There are 2 EU standards applicable for wood products in buildings:

1. EN 13964:2004
Suspended ceilings requirements and test methods
2. EN 13501
The Euroclass test for fire safety.

Shiluvit ceilings are CE certified for both standards.

Our classification is B-s2,d0.

Oranit is authorized to mark Shiluvit wood ceiling with the CE labels.

The wood profiles are treated in an autoclave with special fire retardant materials. A 3-phase process of vacuum, pressure and vacuum ensures that the fire retardant materials penetrate the wood and give it the properties needed for fire safety.

The fire retardant material is transparent and is 100% environmentally friendly.

Environment policy

It is our goal and commitment to use environmentally safe materials and purchase the wood from sustainable forests only.



Wood: Oranit Ltd. is PEFC COC certified. It means that our products are made of wood from sustainable forests, legally harvested with the inspection of PEFC council.

Oranit is ready for the new EUTR regulations (EU Timber Regulations), with all relevant documentation to prove legal wood sources.

Fire retardant: Environmentally friendly material by an authorized European manufacturer.

Varnish and stains: We apply water based varnish and stains only, no polyurethane or thinners are used!

SHILUVIT panels – maintenance

All Shiluvit ceilings types are easy to dismantle for maintenance.

Cleaning can be done by a wet cloth.

Wall panels can be vacuumed or cleaned with a wet cloth.

Storage

SHILUVIT panels should be stored horizontally and leveled without direct connect to the concrete floor. Humidity should not exceed 65°. No direct UV, maximum temperature 28°C



Wood species

We use several standard wood species. All are from sustainable forests. Upon request we can use other wood species.

Our standard wood species:



American Southern Yellow Pine.



American Maple.



American Yellow Poplar.



European Beech



American Red Oak.



Nordic Pine.

If we are asked to produce an order with exotic wood species from controversial areas, we always offer to substitute it with a wood species from a sustainable forest, stained to create the closest imitation to the requested appearance.



Gemeentehuis Hardenberg - Holland
Architecten Cie - OTH Architecten



Total A31 Dijon - France
Marc Nicolas Architecte

Acoustics:

Thanks to the open structure of the panels, there is a high exposure to any acoustic material applied from above, giving the designers or acoustics engineers the freedom to determine the requested acoustics level.



Varnishing and colouring



De Wienslag , Rotterdam - Holland
Architecten SP & Partners - Topos Architecten



Beit Halochem, Beer Sheva - Israel
Kimmel Eshkolot architects



FIFPro , Hoofddorp -Holland
Architectenbureau Paul de Ruiter



Het Zonnehuis, Zwolle - Holland
Architectenbureau RAU

Staining colours

Oranit has its own spraying line for finishing and coating. We can varnish the ceilings with transparent lacquer or stain it upon the requested colour.

Type of varnish and staining:

We use water based stains only! This means that the varnish is absolutely environmentally friendly, odorless, and is not flammable. No polyurethane or thinners are used.

UV protected:

The material we use has UV protection properties. Even if the coated wood is exposed to sun light, there will be no discoloration.

Outdoor use and swimming pools:

For outdoor projects, we add a special component to the coating solution. This gives the wood a special protection for outdoor roofed ceilings or for humid environments like swimming pools.



SHILUVIT- Standard ceilings panels

600X600mm panel

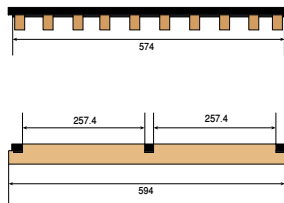
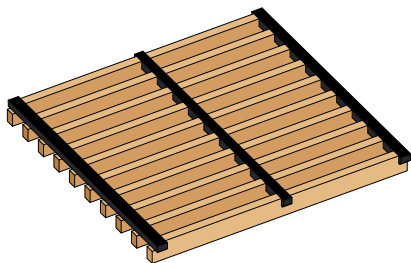

600X1200mm panel

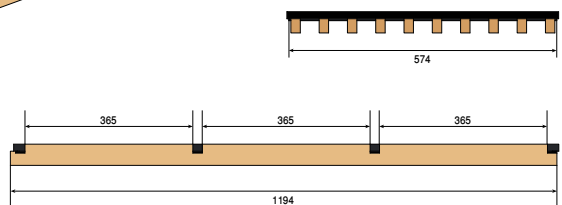
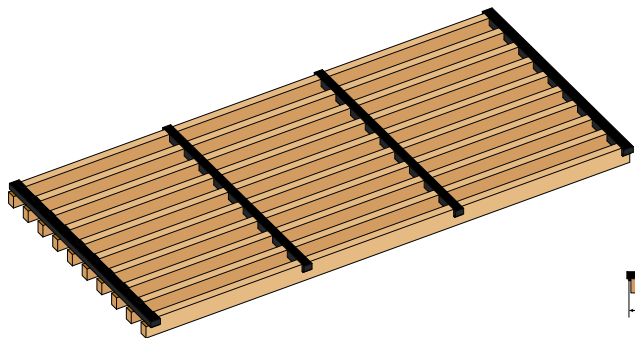

600X1800mm panel

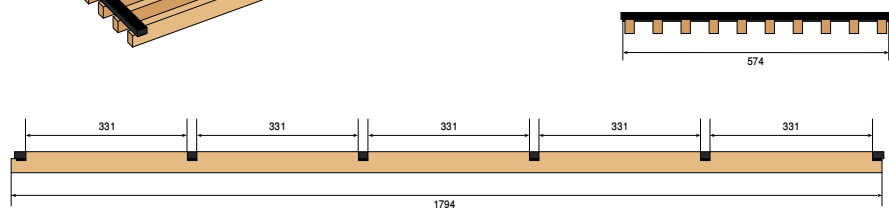
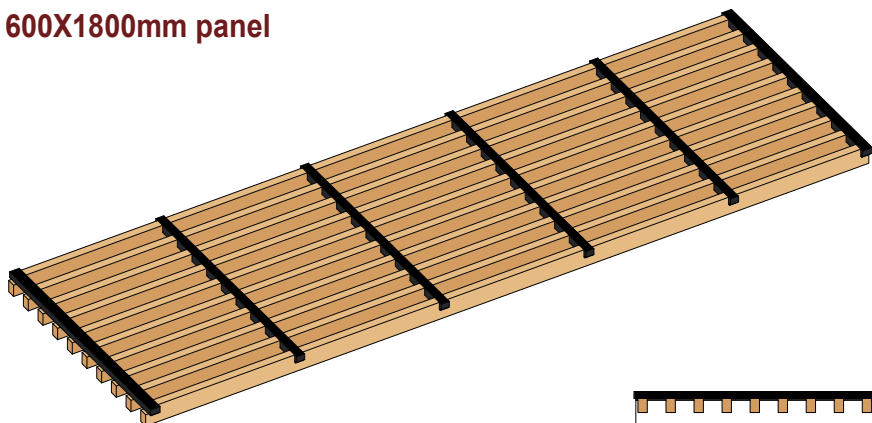

SHILUVIT linear ceilings types

The average weight is 8-10 /m²

The exact weight is the combination of the ceiling type and the wood species.

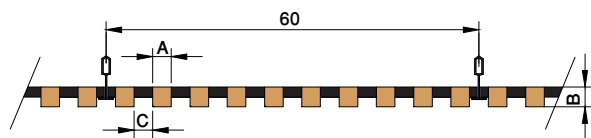

Item no.	A	B	C
7-330	30	30	30

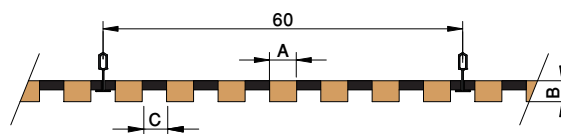

Item no.	A	B	C
7-503	45	35	40

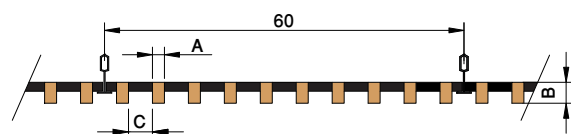

Item no.	A	B	C
7-500	20	35	40

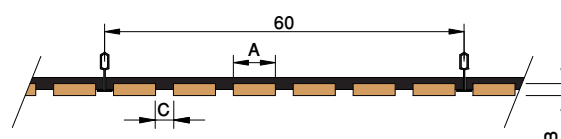

Item no.	A	B	C
7-600	70	20	30

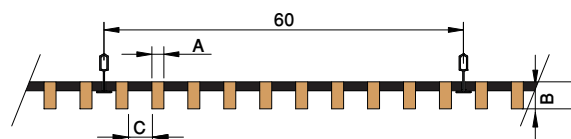

Item no.	A	B	C
7-501	20	45	40

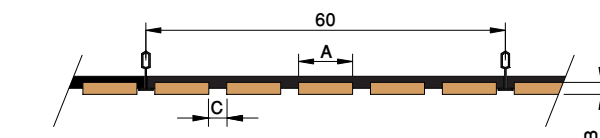

Item no.	A	B	C
7-601	90	20	30

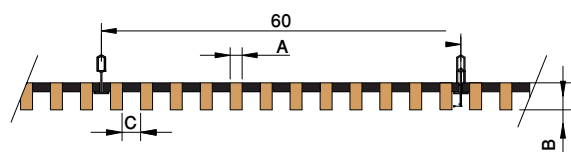

Item no.	A	B	C
7-501A	20	45	30

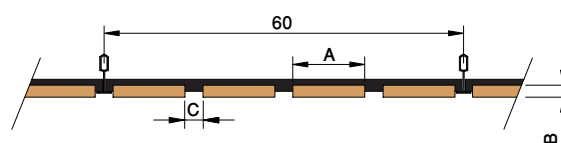

Item no.	A	B	C
7-602	120	20	30

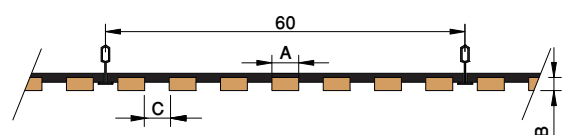

Item no.	A	B	C
7-502	45	22	40

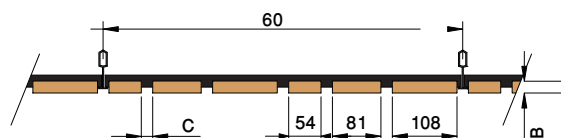

Item no.	A	B	C
7-603	var.	20	19



Panels with openings for light fixtures.

The panels can be easily cut in order to integrate lights fittings, sprinklers, loudspeakers or air condition openings.

We can provide adaptors made of veneered MDF with the requested diameter to fit any fixture.

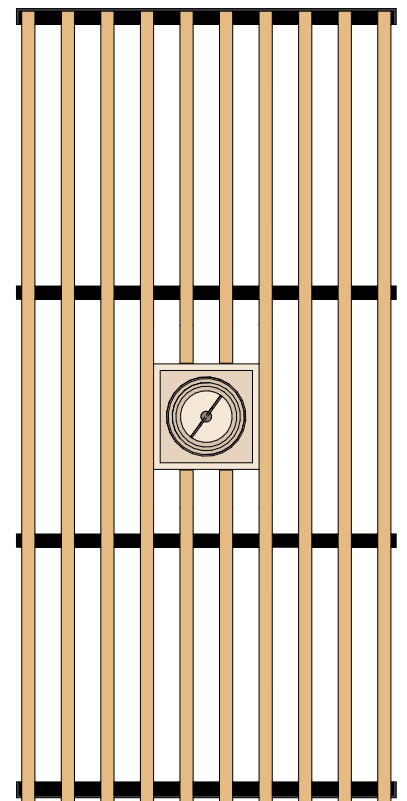
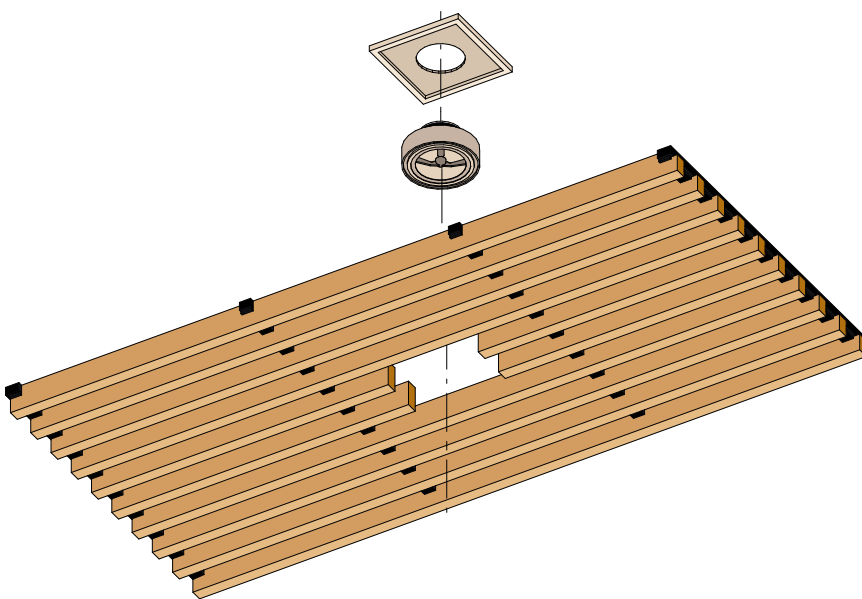

SHILUVIT wood ceilings installation

One of the key principles of the SHILUVIT panels' design was achieving the quickest and easiest installation possible.

SHILUVIT panels are installed on regular T24 or T15 suspension systems, the most common and easy to use systems available. No special tools or rails are needed! It makes both installation and dismantling for maintenance very quick and easy, saving lots of work hours and creating a high value-for-money product, taking into account installation, maintenance and purchase costs.

The installed ceilings create an elegant, clean, monolithic look in spite the fact that they consist of many panels. There is only a small gap of 5mm between the panels on the longer side, to allow wood expansion and easy dismantling.

Installation drawing

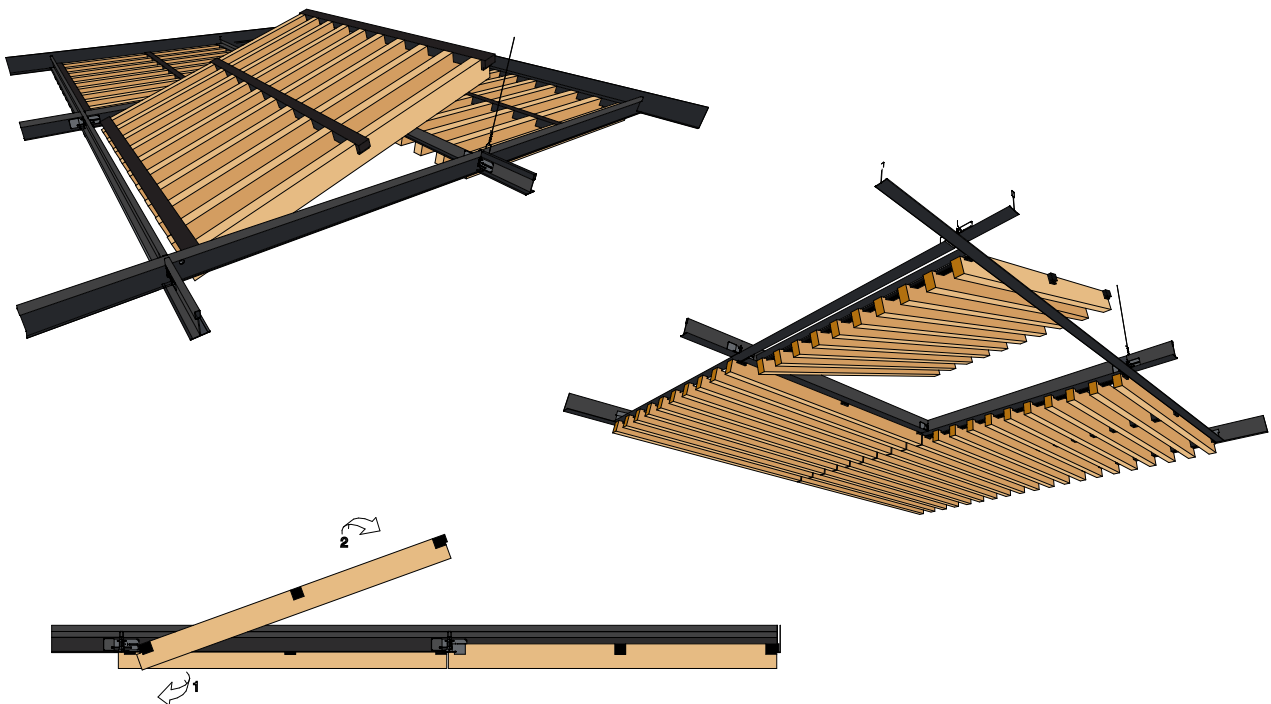

SHILUVIT wood ceilings installation, step by step

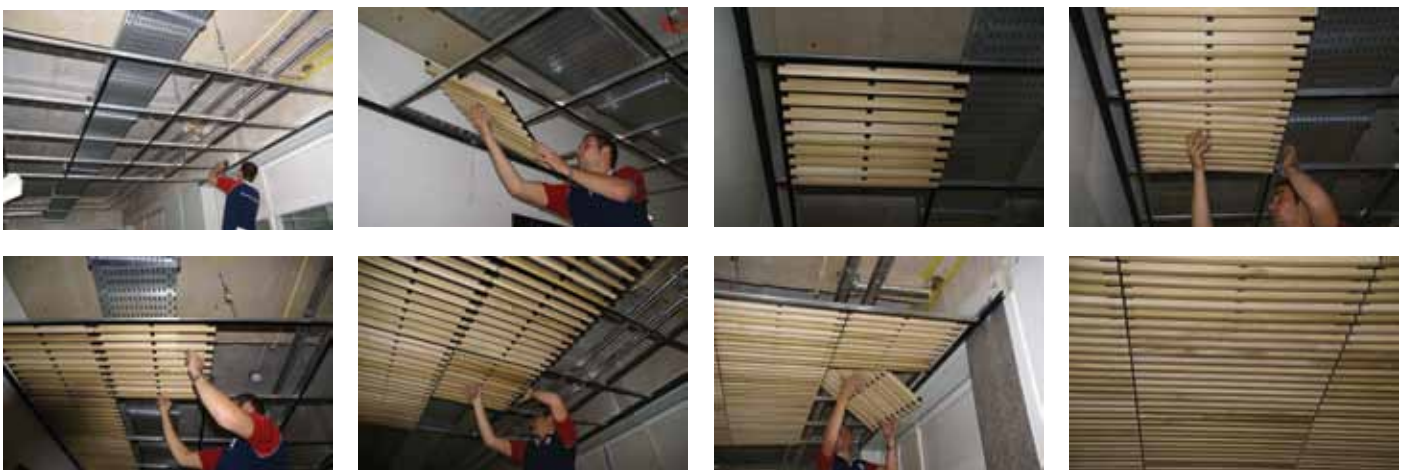

SHILUVIT wall systems

Following the leading idea of easy and quick installation, we created a very simple system using basic, low-cost fixing materials.

The panels are fixed to a black painted infrastructure using black screws through the black cross ties of the panel.

The installed panels create a sophisticated look in which the linear wood pieces seem to be hanging freely, with no metal connectors or joints visible.

Naturally, wall panels can be longer and produced according to requested length.

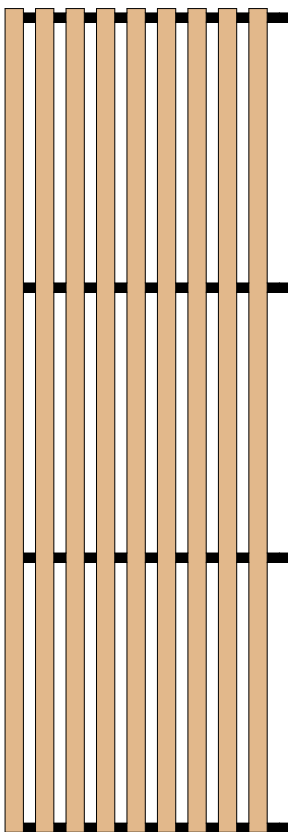
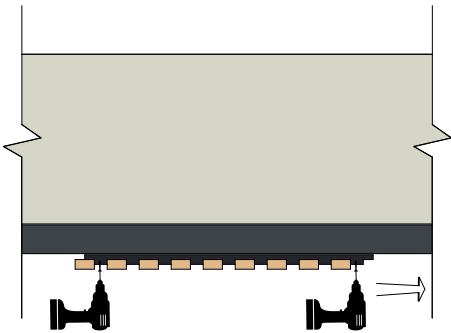

Vierpolders, Brielle - Holland
V.V.K.H Architecten

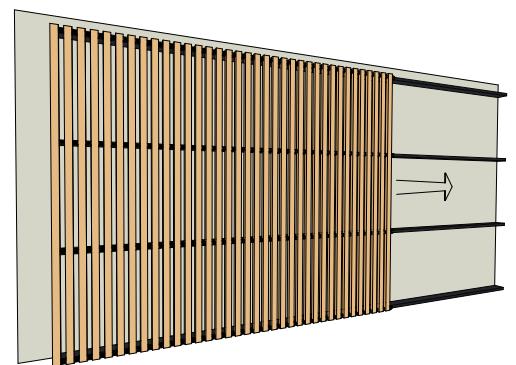
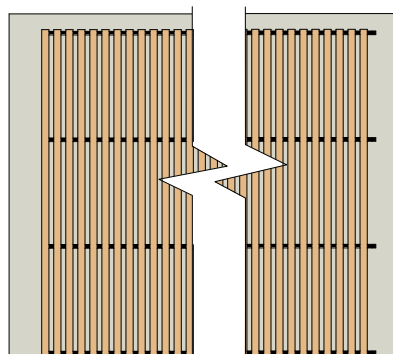



't Scureken, Heeze - Holland
Versleuuen Ontwerpers



De Wienslag, Rotterdam - Holland
Architecten SP & Partners - Topos Architecten



Rehovot Residence - Israel
Meir Gal, architect



SHILUVIT – curved ceilings and walls

Oranit developed a simple and easy system of installation for curved ceilings and curved walls.

Following our basic idea of simplicity and using low-cost suspension materials, we just changed the wood cross ties to black flexible cross ties that can follow the requested radius.

The flexible cross ties are fire class certified.

The SHILUVIT panels are fixed to a curved metal infrastructure that is commonly used for curved gypsum. The flexible ties enable the panel to be curved to the same radius, and then by using black screws - fasten it to the structure.

Dismantling for maintenance can be easily done by unscrewing the necessary screws.

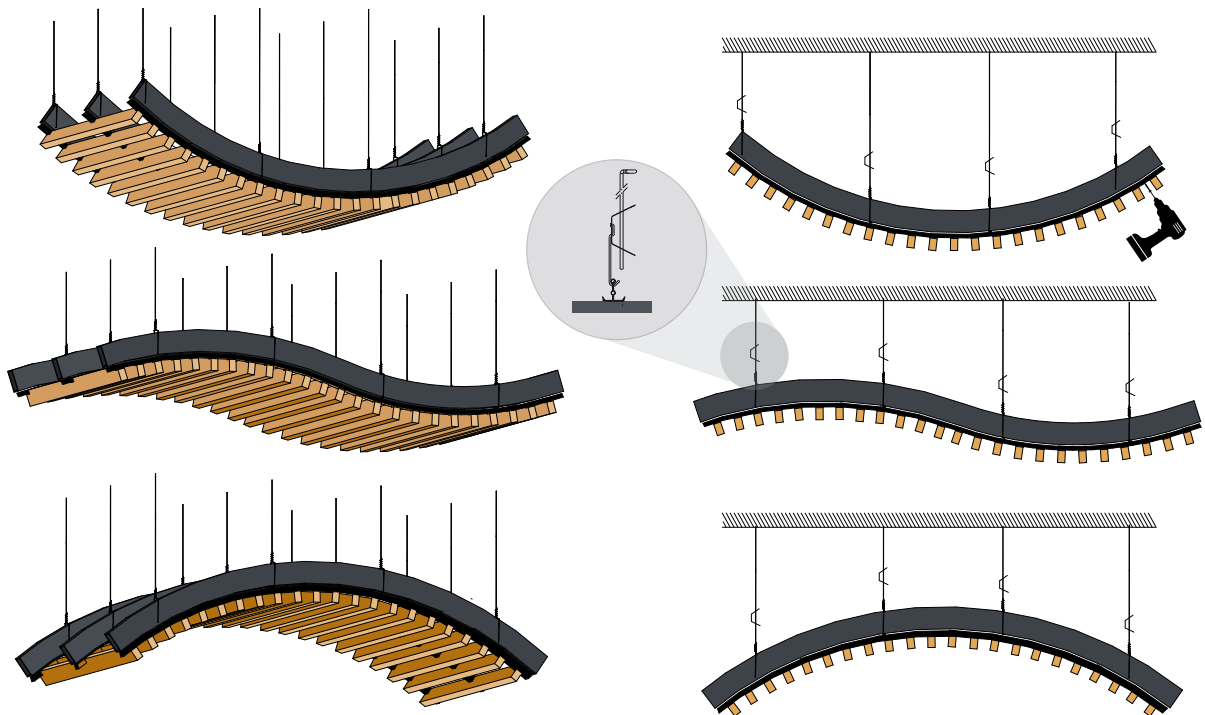

SHILUVIT – curved ceilings and walls



Duran Hall, Rehovot - Israel
Yohanan Beery architect



Faculté de Médecine, Paris - France
Cannal3 Architecte



SHILUVIT ceiling for external use and swimming pools

Oranit has a long and successful experience with projects of outdoors, roofed installations, and indoor swimming pools.

In both cases, special care should be taken to protect the wood from the high humidity environment.

For such projects, we spray special varnish on all sides of the panel, to prevent humidity from penetrating the wood.

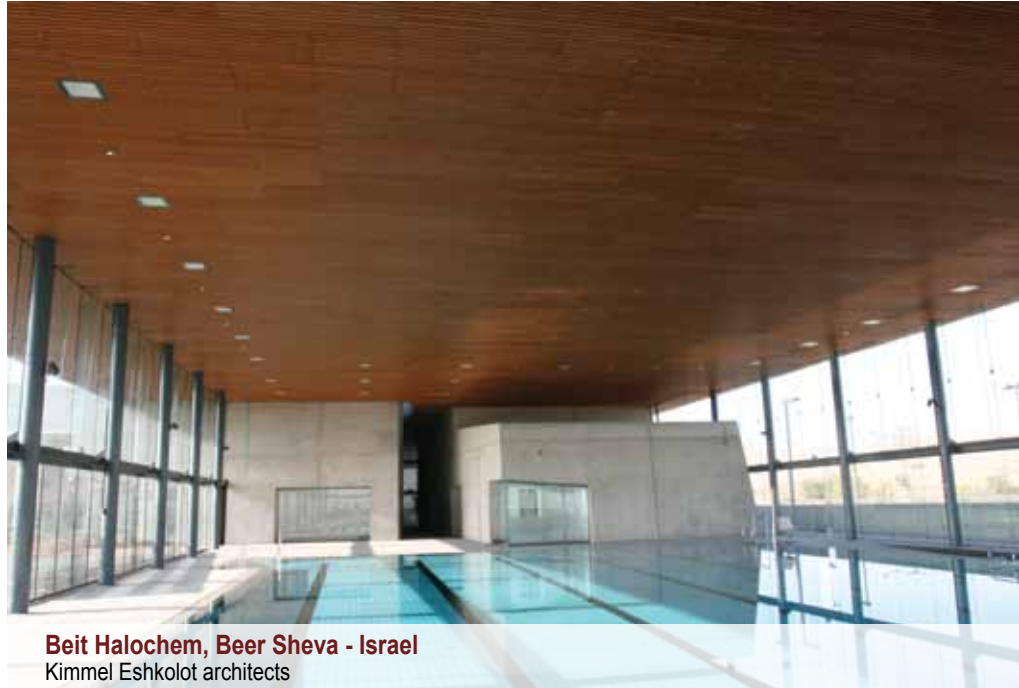

Beit Halochem, Beer Sheva - Israel
Kimmel Eshkolot architects



Gare de Boissy Saint Léger – France
AREP Architecte



MTG center Gdansk – Poland
Piotr Mazur Fort architectes



SHILUVIT panels for corridors

We developed a unique, easy-to-use panel especially for corridors.

It can be installed on angles running along the walls, with T bars between the panels to keep them straight.

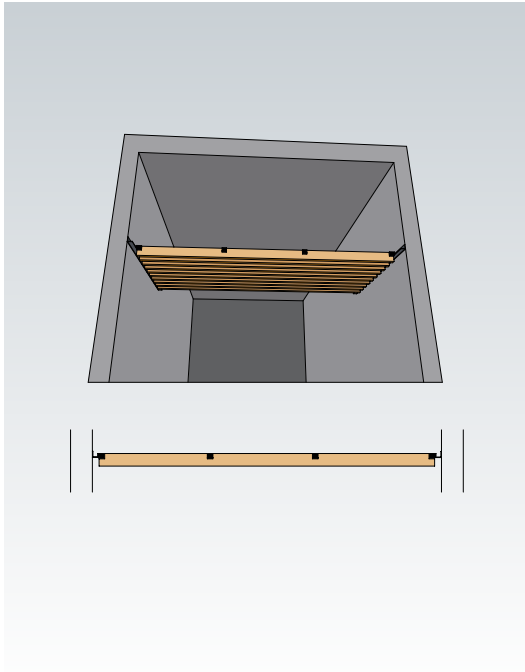

SHILUVIT Special designs

Oranit is always open to new ideas and designs requested by architects.

Apart of our standard panels, we produced custom-made panels according to architects' special specifications, to follow special building designs, giving ultimate solutions for unique shapes.

As all design and production is done at Oranit, we always do our best to provide the architect's requests for shapes, dimensions, colours etc.



Aéroport de Toulouse - France
Cardete et Huet Architecte





Lycée Fustel de Coulanges , Massi – France
Architecte: X-TU Anouk Legendre / Nicolas Desmazières



Gemeentehuis Hardenberg - Holland
Architecten Cie - OTH Architecten

